

ABF-260/100W PA6 V0

Installation Manual

Applies to Part Numbers:

TUN-570285

ABF-260/100W PA6 V0

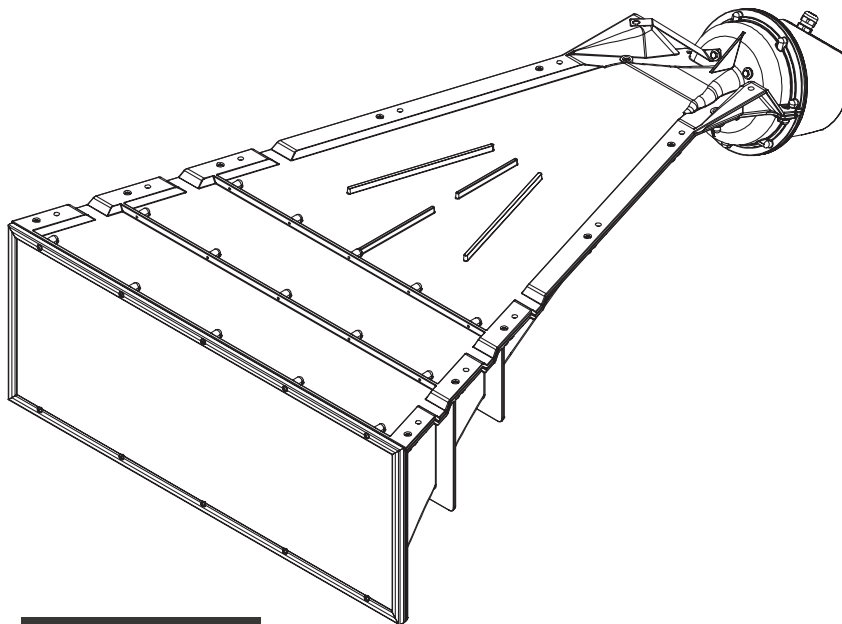

EN54-24
CERTIFIED

Delivering Clear and Intelligible Messages

AXYS[®]
TUNNEL
by **HARMAN**

TABLE OF CONTENTS

TABLE OF CONTENTS 2

EC DECLARATION OF CONFORMITY 3

DECLARATION OF PERFORMANCE 4

USER’S NOTICE AND DISCLAIMER 7

1. IMPORTANT SAFETY INSTRUCTIONS 8

2. INTRODUCTION 9

 UNPACKING10

 OVERVIEW10

3. INSTALLATION GUIDE 11

 PREPARING FOR INSTALLATION11

 MECHANICAL INSTALLATION11

 FIXING TO A CURVED ROOF12

 NON-FLUSH INSTALLATION12

4. ELECTRICAL CONNECTIONS 13

 CABLE SPECIFICATIONS13

 WIRING DETAILS14

 MONITORING15

5. APPENDIX 16

 ABF-260 HIGH PASS FILTER16

 MAINTENANCE AND CLEANING16

EC DECLARATION OF CONFORMITY



This document confirms that the product manufactured by Harman Professional Kft. and described hereafter is in conformity with the following directive(s) and meets the requirements of the following standard(s):

Applicable directive(s)	LVD 2014/35/EU (see note 1)		
Applicable standard(s)	Not applicable	Provided options	Not applicable

Product details:

Construction product description	Loudspeaker for voice alarm systems for fire detection and fire alarm systems for buildings
Product model/type	ABF-260

Document references:

Datasheet(s)	202103/ABFPA6VO_D_2.1 (ABF-260 datasheet)
Other references	Not applicable

Manufacturer:

Name	Harman Professional Kft.
Address	Szilva u. 1-3. H-7632 Pecs Hungary
Web	www.axystunnel.com
Authorized by	
Place and date of issue	Pecs – January 28, 2021

Notes:

1. Only if connected in accordance with the manufacturer's instructions to mains operated audio equipment with safety properties according to the relevant harmonized standards.

Declaration of Performance
According to Construction Products Regulation (CPR) 305/2011
No: 2014-001

1.	Unique identification code of the product-type:	
	ABF-260	
2.	Type, batch or serial number or any other element allowing identification of the construction product as required pursuant to Article 11(4):	
	Each product has a unique serial number specified on the product label	
3.	Intended use or uses of the construction product, in accordance with the applicable harmonised technical specification, as foreseen by the manufacturer:	
	Construction product	Loudspeaker for voice alarm systems for fire detection and fire alarm systems for buildings
	Intended use	Fire safety
	Harmonised technical specification	EN 54-24:2008 Fire detection and fire alarm systems Part 24: Components of voice alarm systems - Loudspeakers
	Provided options	Type B
4.	Name, registered trade name or registered trade mark and contact address of the manufacturer as required pursuant to Article 11(5):	
	Name	Harman Professional Kft.
	Address	Szilva u. 1-3. H-7632 Pecs Hungary
	Web	www.axystunnel.com
	Branding/Trade name	AXYS®

5.	<p>Where applicable, name and contact address of the authorised representative whose mandate covers the tasks specified in Article 12(2):</p> <p>Not applicable</p>												
6.	<p>System or systems of assessment and verification of constancy of performance of the construction product as set out in Annex V:</p> <p>System 1</p>												
7.	<p>Declaration of performance concerning a construction product covered by a harmonised standard:</p> <p>Notified body details:</p> <table border="1" data-bbox="280 723 1481 1256"> <tr> <td data-bbox="280 723 756 853">Name</td> <td data-bbox="756 723 1481 853">Scientific and Research Centre for Fire Protection named after Józef Tuliszkowski - National Research Institute</td> </tr> <tr> <td data-bbox="280 853 756 936">Identification</td> <td data-bbox="756 853 1481 936">CNBOP-PIB-1438</td> </tr> <tr> <td data-bbox="280 936 756 1066">Address</td> <td data-bbox="756 936 1481 1066">Nadwislanska 213 Street 05-420 Józefów Poland</td> </tr> <tr> <td data-bbox="280 1066 756 1128">Web</td> <td data-bbox="756 1066 1481 1128">www.cnbop.pl</td> </tr> <tr> <td data-bbox="280 1128 756 1191">EC certificate of conformity</td> <td data-bbox="756 1128 1481 1191">1438-CPR-0748</td> </tr> <tr> <td data-bbox="280 1191 756 1256">ITT report</td> <td data-bbox="756 1191 1481 1256">No. 289/BA/20</td> </tr> </table>	Name	Scientific and Research Centre for Fire Protection named after Józef Tuliszkowski - National Research Institute	Identification	CNBOP-PIB-1438	Address	Nadwislanska 213 Street 05-420 Józefów Poland	Web	www.cnbop.pl	EC certificate of conformity	1438-CPR-0748	ITT report	No. 289/BA/20
Name	Scientific and Research Centre for Fire Protection named after Józef Tuliszkowski - National Research Institute												
Identification	CNBOP-PIB-1438												
Address	Nadwislanska 213 Street 05-420 Józefów Poland												
Web	www.cnbop.pl												
EC certificate of conformity	1438-CPR-0748												
ITT report	No. 289/BA/20												
8.	<p>Declaration of performance concerning a construction product for which a European Technical Assessment has been issued:</p> <p>Not applicable</p>												

9.	Declared performance:		
	Essential characteristics	Performance	Harmonised technical specification EN 54-24:2008 - Type B
	Frequency response limit	Passed	Section 4.2
	Durability	Passed	Section 4.3
	Reproducibility	Passed	Section 5.2
	Rated impedance	Passed	Section 5.3
	Horizontal and vertical coverage angles	Passed	Section 5.4
	Maximum sound pressure level	Passed	Section 5.5
	Marking and data	Passed	Section 4.5
	Rated noise power (durability)	Passed	Section 5.6
	Dry heat (operational)	Passed	Section 5.7
	Dry heat (endurance)	Passed	Section 5.8
	Cold (operational)	Passed	Section 5.9
	Damp heat, cyclic (operational)	Passed	Section 5.10
	Damp heat, steady state (endurance)	Passed	Section 5.11
	Damp heat, cyclic (endurance)	Passed	Section 5.12
	Sulfur dioxide corrosion (endurance)	Passed	Section 5.13
	Shock (operational)	Not applicable	Section 5.14
	Impact (operational)	Passed	Section 5.15
	Vibration, sinusoidal (operational)	Passed	Section 5.16
Vibration, sinusoidal (endurance)	Passed	Section 5.17	
Enclosure protection	Passed	Section 5.18	

10.	The performance of the product identified in points 1 and 2 is in conformity with the declared performance in point 9.	
	This declaration of performance is issued under the sole responsibility of the manufacturer identified in point 4.	
	Place and date of issue	Pecs - January 28, 2021

USER'S NOTICE AND DISCLAIMER:

No part of this manual including the software described in it may be reproduced, transmitted, transcribed, stored in a database system or translated without the express written permission of Harman Professional Kft.

Documentation kept by the end user for back-up purposes is excluded from the above.

All products and corporate names mentioned in this manual may be registered trademarks or copyrights of their respective companies. They are used here for indicative purposes only.

The information contained in this manual has been carefully checked for accuracy; however no guarantee is given with respect to its correctness. Harman Professional Kft accepts no responsibility or liability for any errors or inaccuracies that may appear in this manual or the products and software described in it.

Specifications and information contained in this manual are subject to change at any time without notice.

© 1998-2021 Harman Professional Kft. All rights reserved.

1. IMPORTANT SAFETY INSTRUCTIONS



This symbol is intended to alert you to the presence of uninsulated dangerous voltages within the product's enclosure that may be of sufficient magnitude to constitute a risk of electric shock.



This symbol is used throughout this manual and is intended to alert you to the presence of important instructions.

- 1) Read these instructions.
- 2) Keep these instructions.
- 3) Heed all warnings.
- 4) Follow all instructions.
- 5) Do not use this apparatus near water.
- 6) Clean only with dry cloth.
- 7) Do not block any ventilation openings. Install in accordance with the manufacturer's instructions.
- 8) Do not install near any heat sources such as radiators, heat registers, stoves, or other apparatus (including amplifiers) that produce heat.
- 9) Only use attachments/accessories specified by the manufacturer.



10) Use only with the cart, stand, tripod, bracket or table specified by the manufacturer, or sold with the apparatus. When a cart is used, use caution when moving the cart/apparatus combination to avoid injury from tip-over.

11) Refer servicing to qualified service personnel. Servicing is required when the apparatus has been damaged in any way, liquid has been spilled or objects have fallen into the apparatus, the apparatus does not operate normally, or has been dropped.



Warning -To reduce the risk of fire or electric shock, do not expose this apparatus to rain or moisture.



Warning -The installer should ensure that the mechanical mounting method employed should be capable of supporting four times the weight of the unit (i.e., with a safety factor of 4).



Warning -Equalisation boosts below 350 Hz frequency could damage/shorten the life expectancy of the compression driver. No equalisation boosts should be applied below 350 Hz. In addition a 4th order 350 Hz high pass filter should be applied in the output signal path of the ABF-260. The high pass filter specification can be found in the appendix of this manual.

2. INTRODUCTION

This manual describes the recommended installation procedures for the AXYS® ABF-260 range of loudspeakers.

This manual is valid for the ABF-260/100W PA6 V0.

The ABF-260 is a high power, low distortion horn loudspeaker intended for use in Public Address and Voice Alarm (PA/VA) systems in locations with high ambient noise levels. It is particularly suitable for installation in reverberant spaces such as road tunnels where high noise levels are normal, but speech transmission with good intelligibility is required in emergency situations.

The AXYS® ABF-260 employs the patented principle of Acoustic Boundary Flare (ABF) geometry. It is designed to be mounted directly on the roof of the tunnel; the roof in front of the flare then acts as an acoustic waveguide, resulting in a coherent wavefront. It is this coherence which ensures that high sound pressure levels (SPLs) and good intelligibility are maintained even some distance from the loudspeaker. For this reason, correct loudspeaker placement and orientation are critical, as the desired coverage will not be achieved otherwise.

The ABF-260 is designed for use in 100 V audio distribution systems. It is not suitable for direct connection to power amplifiers equipped only with outputs suitable for driving low impedance (4 - 8 Ω) loads.

This manual covers:

- Mechanical installation of the loudspeaker.
- Wiring and connection details.
- Identification of internal components (in Appendix).

UNPACKING

The ABF-260 is shipped in a cardboard packing case.

In addition to the horn loudspeaker itself, the shipment also includes:

- Production measurement report
- Safety leaflet

OVERVIEW

If installing an ABF-260 for the first time, it may be helpful to spend a few moments identifying the unit's main features after unpacking*.

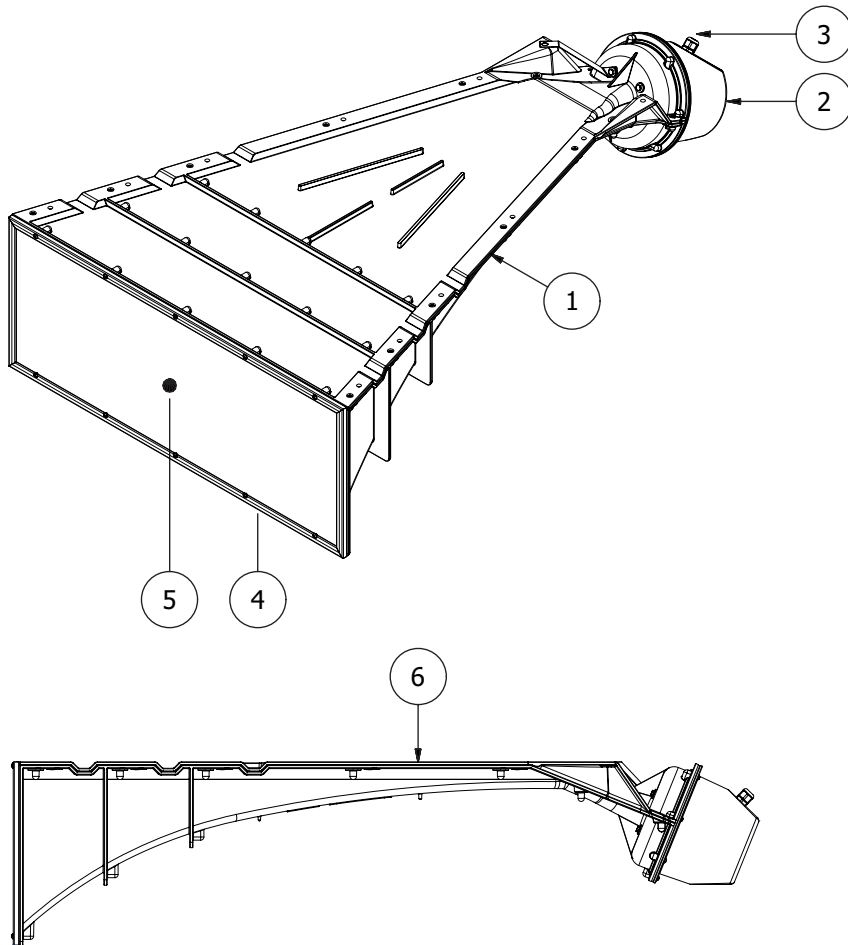

fig.1: ABF-260 main features.

- | | |
|------------------------|--------------------------|
| 1. Horn flare | 4. Water resistant grill |
| 2. Rear cover | 5. Horn exit |
| 3. Cable gland PG 13.5 | 6. Mounting surface |

*Consult the product datasheet for additional details.

3. INSTALLATION GUIDE

PREPARING FOR INSTALLATION

It is assumed that the installation site (e.g. tunnel) has been the subject of extensive acoustic analysis prior to the actual installation. The analysis should have assessed the acoustic conditions in the tunnel and defined the operating scenarios (Local/All call, traffic speed, ventilation active/inactive etc) for the PA/VA system. The minimum speech intelligibility requirements must be met for each scenario. The acoustic properties of the tunnel's interior surfaces (acoustic absorption and scattering coefficients) and the expected background noise levels due to the traffic and/or ventilation system should also have been established. More information regarding the acoustic design procedure, including design guidelines, is available at www.axystunnel.com.

Various acoustic modelling software applications are available; for example CATT-Acoustic® modelling is suitable when accurate predictions of the STI (Speech Intelligibility Index) are necessary.

Nearly all tunnel installations will need to employ multiple ABF-260 units to obtain satisfactory sound coverage. The acoustic design procedure will have identified the number of ABF-260s required and the optimum physical location for each to accurately achieve the desired acoustic coverage. In particular, the height above the roadway, and any mechanical mounting angles will have been specified. 50 m linear spacing between units is typical, but two or more units may be required at each position when the overall tunnel width is more than 12 m.

The installer should confirm that he/she has all necessary information relating to the location and physical orientation of all ABF-260 units making up the system. It is important to recognise that even small deviations from the calculated positions can adversely affect the desired acoustic coverage.

MECHANICAL INSTALLATION

Location

The ideal mounting situation for the ABF-260 is with the upper surface of the horn secured flush to the mounting surface (the tunnel roof). If the roof is curved, a totally flush fitment may be unachievable; see "Fixing to a curved roof" in this section. Tunnel infrastructure may also preclude a flush fitment; see "Non-flush installation" at the end of this section.

The ABF-260 should be mounted so that the flare of the horn faces the oncoming traffic. If it is found that tunnel infrastructure items (lights, traffic signs, fans, etc.) are within 5 m of the horn flare and in line with the horn, an alternative mounting location should be found. In such cases, the installer must contact the acoustic designer for guidance before proceeding with the installation.



Do not mount the ABF-260 in the vicinity of high pressure deluge / sprinkler system water outlets. Any water outlets of the sprinkler system should not spray directly into/onto the ABF-260.

Fixings

Fixing is via the twelve 9 mm mounting holes around the edge of the upper surface. It is advised to use the 8 fixing points located in pairs at a distance of respectively 77, 665, 939 and 1104 mm from the front side of the unit as indicated in fig.2. M8 screws or bolts should be used, of a length appropriate to the type of mounting employed (see below).



The weight of the ABF-260 is 21 kg, and a safety factor of 4 should be allowed when checking the safe load capability of the mountings.

The diagram on the following page (fig.2) gives the dimensions required for marking the mounting hole locations on the roof. When marking out for the holes, take care that the hole positions take into account any mounting angle specified for the horn by the acoustic specification.

The roof mountings can be in the form of threaded inserts, commercially available as "Rawlbolts", or similar. An alternative approach is to inject a fire resistant chemical screw fixing compound into the hole and fix the loudspeaker using 8 mm diameter hex-head coach screws. The horn may need to be supported during the compound's setting phase (curing time).

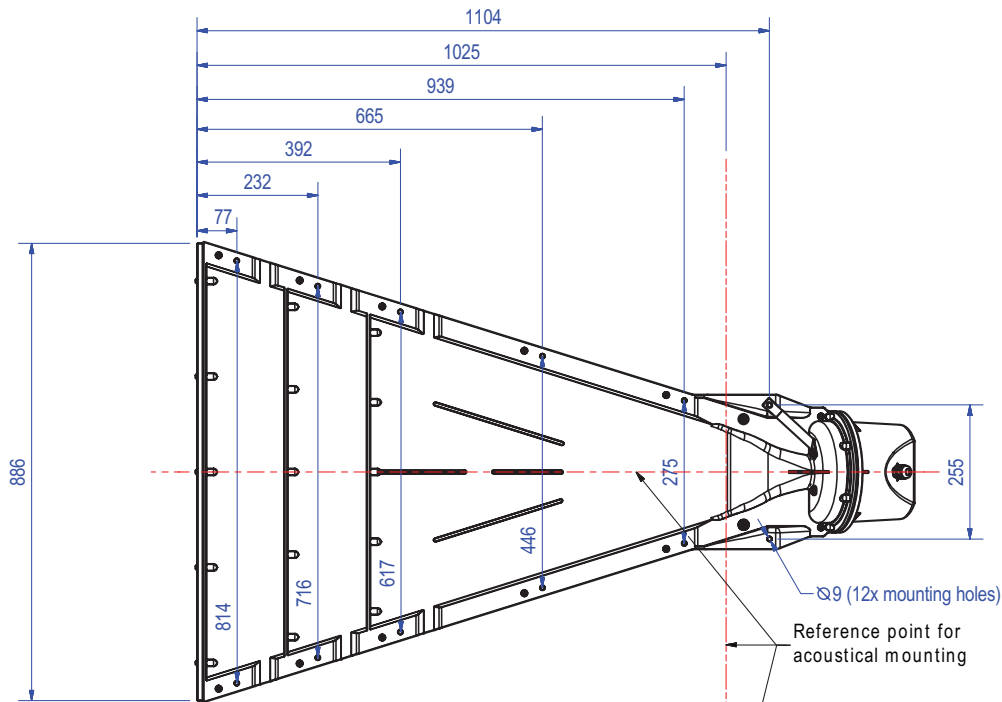
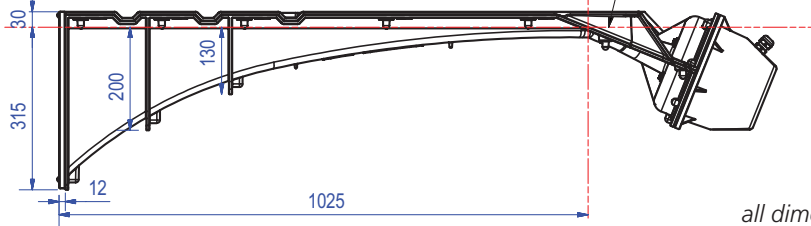

fig.2: Mechanical references.



all dimensions are in mm

FIXING TO A CURVED ROOF

In a tunnel with a curved roof, a totally flush fitment will be unachievable, the degree of deviation being dependent on the radius of curvature. In practice, the result will be a gap between the horn's upper surface and the tunnel roof, which will be at a maximum along the longitudinal centreline of the horn. If this gap is less than 2.5 cm no serious departure from the unit's specified performance will result. However a gap larger than this will impair the acoustic performance, and an alternative mounting method should be found (see hereafter).

NON-FLUSH INSTALLATION

If an acceptably flat fitment to the tunnel roof is unobtainable, either due to the tunnel's curvature or to lack of access to the specified mounting position because of signs, gantries, trunking or other infrastructure items, it may be necessary to mount the ABF-260 some distance below the tunnel roof. This can generally be achieved using Unistrut® or similar standard fixing systems. However, because of the ABF-260's "extended waveguide" principle of operation, its performance will be degraded significantly if it is "hung" in this manner in free air. This can be remedied by fixing the ABF-260 to a boundary plate (a flat board made of a suitable fire resistant material), to simulate the effect of the tunnel roof in a flush fixing. The board should be substantially larger than the horn, and a minimum size of 2 x 1 m is from the exit of the horn is recommended.

4. ELECTRICAL CONNECTIONS

CABLE SPECIFICATIONS

The maximum permissible cable length is dependent on the wire gauge of the cores. Too high a cable resistance, resulting either from too small a core diameter, an excessively long cable length, or a combination of the two, will result in an unacceptable level of signal loss between the power amplifier and the ABF-260.

The maximum signal loss that can be tolerated is depending on the design constraints of the installation (e.g. allowed reduction of maximum SPL that can be achieved). The tables below list the cable lengths which result in a 1 dB respectively 3 dB signal loss for various core diameters, and thus represent the maximum cable length which can be employed in each case. Installers should recognise that these are absolute maximum figures for one ABF-260 per power amplifier, and work well within these limits. Note that cable capacitance can become an issue as well considering impedance load monitoring with HF pilot tones, however detailed cable impedance modelling is not within the scope of this document.



The terminal block of the ABF-260 is rated for wires with a conductor cross-section of 2.5 mm². Larger cross-sections are possible depending on the termination (maximum 6 mm² for a stranded wire with end sleeve). An external junction box might be required to interface between a cable with larger wire cross-section and the terminal block.

Wire cross-section	1.0 dB loss	3.0 dB loss
0.50 mm ²	142 m	479 m
0.75 mm ²	212 m	718 m
1.00 mm ²	283 m	957 m
1.50 mm ²	425 m	1436 m
2.50 mm ²	708 m	2393 m
4.00 mm ²	1132 m	3828 m
6.00 mm ²	1699 m	5743 m

Table 1. Maximum cable length for a specified maximum loss (metric wire) - 100 W tap.

Wire cross-section	1.0 dB loss	3.0 dB loss
0.50 mm ²	283 m	957 m
0.75 mm ²	425 m	1436 m
1.00 mm ²	566 m	1914 m
1.50 mm ²	849 m	2871 m
2.50 mm ²	1415 m	4786 m
4.00 mm ²	2265 m	7657 m
6.00 mm ²	3397 m	11485 m

Table 2. Maximum cable length for a specified maximum loss (metric wire) - 50 W tap.

Wire	1.0 dB loss	3.0 dB loss
22 AWG	92 m	312 m
21 AWG	116 m	392 m
20 AWG	147 m	496 m
19 AWG	185 m	625 m
18 AWG	233 m	788 m
17 AWG	294 m	995 m
16 AWG	371 m	1245 m
15 AWG	467 m	1579 m
14 AWG	589 m	1991 m
13 AWG	742 m	2508 m
12 AWG	937 m	3168 m
11 AWG	1181 m	3991 m

Table 3. Maximum cable length for a specified maximum loss (AWG wire) - 100 W tap.

Wire	1.0 dB loss	3.0 dB loss
22 AWG	185 m	624 m
21 AWG	232 m	785 m
20 AWG	293 m	992 m
19 AWG	370 m	1250 m
18 AWG	466 m	1575 m
17 AWG	589 m	1991 m
16 AWG	742 m	2508 m
15 AWG	934 m	3159 m
14 AWG	1178 m	3982 m
13 AWG	1483 m	5015 m
12 AWG	1874 m	6336 m
11 AWG	2361 m	7982 m

Table 4. Maximum cable length for a specified maximum loss (AWG wire) - 50 W tap.

WIRING DETAILS

Electrical connection to the ABF-260 is made via a terminal block located inside the rear cover. Screw terminals are provided for either 100 W or 50 W tap connection. The terminals are rated for wires with a conductor cross-section of 2.5 mm².

Proceed as follows to connect the ABF-260 to the 100 V line audio feed:



Ensure that the speaker circuit is not active, either turn the amplifier(s) off, or disconnect their outputs.



The numbers between square brackets in the description hereafter refer to the exploded view on page [17](#).

1. Remove the rear-cover [17]. This cover, which contains the electronics assembly, is fixed with seven EJOT PT TX20 stainless steel screws [8]. Note that the rear cover is secured by means of an internal Steel Wire Rope [12] (and figure 5) that is connected to a safety bracket [7] of the horn assembly.
2. Guide the 100 V audio feed cable through the gland [14]. Note that the gland is suitable for a cable with an outer diameter between 6 and 12 mm.
3. Remove the last 5 to 10 cm of the cable jacket and strip the wires (approx. 10 mm).
4. Connect the wires to the terminal block, located on the printed circuit board of the electronics assembly [18] (and figure 6). Note that the terminal block contains 3 terminals labeled '100W', '50W' and '0'. Either use the '100W' and '0', or use the '50W' and '0' connections, as specified by the acoustic designer. Observe correct polarity, the '100W' and '50W' terminals correspond to positive polarity. Tighten the screws and ensure there are no stray strands from the cores.
5. Properly position the cable gasket into the gland [14]. Manually tighten the nut on the gland to lock the cable and to prevent water ingress through the cable entry. Do not overtighten!
6. Re-position the rear cover [17]. Ensure that the gasket [13] is properly positioned and that the rear cover is properly oriented (cable exit at the top). Also ensure that the Steel Wire Rope [12] (and figure 5) cannot make electrical contact with any conductive part.

An improperly positioned gasket or rear cover may compromise the enclosure protection!

Operate accurately in order to prevent excessive water or dust ingress into the rear enclosure.
7. Fasten the screws to a torque value of 0.8Nm [8].
8. Complete the external wiring, respect the applicable installation requirements such as minimum bend radius of the cable.

AMPLIFIER REQUIREMENTS

Harman Professional recommend the use of the AXYS® PB-400 or PB-800 Industry Amplifiers with the ABF-260.

The ABF-260 is rated at 100 watts ('100W' connection) respectively 50 watts ('50W' connection) on the 100 V line system. The amplifier used to drive the horns making up a single loudspeaker circuit must have a power rating sufficient to drive all the loudspeakers. The number of amplifiers to be used in a tunnel system will also be determined in part by life safety consideration of component redundancy and loudspeaker interleaving. A full discussion of these topics is beyond the scope of this document, but they should already have been taken into account by the system designer.

MONITORING

Life safety installations typically have very low duty cycles; that is, they spend the most of their service lives not being used. For this reason, many installations will require permanent loudspeaker monitoring to be implemented to verify the continued operation of the loudspeaker(s).

If the ABF-260 is being driven by an AXYS® PB-400 or PB-800 Industry Amplifier, no additional connections need be made, as these amplifiers include load monitoring as part of their design.

THERMAL PROTECTION

In a PA/VA system, it is important that the failure of a single loudspeaker does not incapacitate the rest of the system.

The ABF-260 incorporates two protection systems to prevent this.

1. A thermal fuse in series with the 100 V input. This is intended as failsafe device, which goes open-circuit if the internal temperature becomes excessive, such as would occur in the event of a fire. Thus a local fire which damages a single speaker on a system does not cause other speakers elsewhere to fail, as the damaged unit is removed from the speaker circuit.
2. A ceramic connector ensures that the terminal will not melt in a fire situation and short out the audio line.

5. APPENDIX

ABF-260 HIGH PASS FILTER

A 4th order Linkwitz-Riley (24 dB/Oct) high pass filter should be applied in the output signal path of the ABF-260.

If the ABF-260 is being driven by an AXYS® PB-400 or PB-800 Industry Amplifier, two output equalisation filters can be cascaded together to form a 4th order Linkwitz-Riley filter.

Each of the two filter sections should be set to the following values;

Type = Highpass

Fc = 350 Hz

Q = 0.707

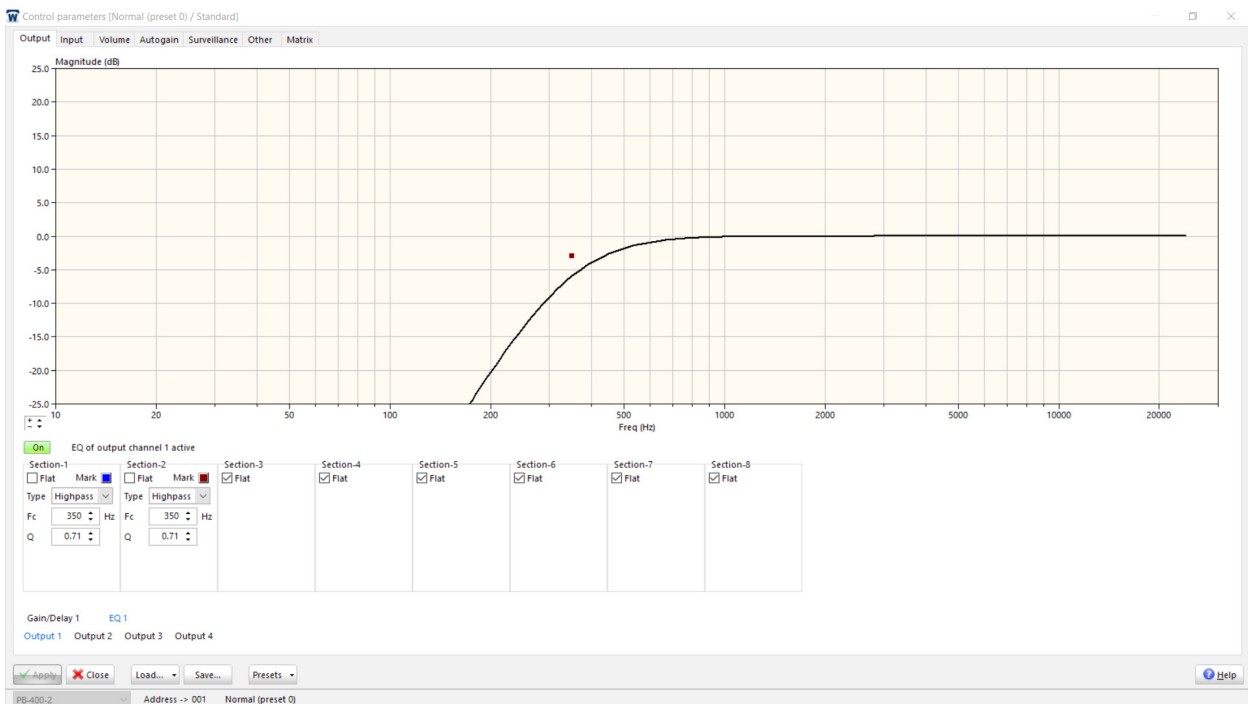

fig.3: Screenshot of applied equalisation to an IndustryAmp PB-400.

MAINTENANCE AND CLEANING

The ABF-260 is designed to operate for an extended duration in a hostile environment. The driver enclosure is sealed and water resistant, and should only need to be removed after installation in the very rare event of component failure. The enclosure and internal electrical components do not require regular maintenance.

An acoustically transparent and water resistant grill is mounted on the horn exit. This grill consists of two perforated stainless steel plates contained within a rubber frame. The grill protects the horn throat from the ingress of

water, bird droppings and other detritus. Regular cleaning of this protection grid might be required in order to avoid deterioration of the acoustical performance of the ABF-260. The required cleaning interval is depending on the environmental classification with respect to dust deposit.

Although the ABF-260 is designed to withstand jet cleaning equipment, such as may be used in tunnel cleaning operations, it is advised to avoid spraying a high pressure/ high rate water flow directly into the horn mouth.

EXPLODED VIEW

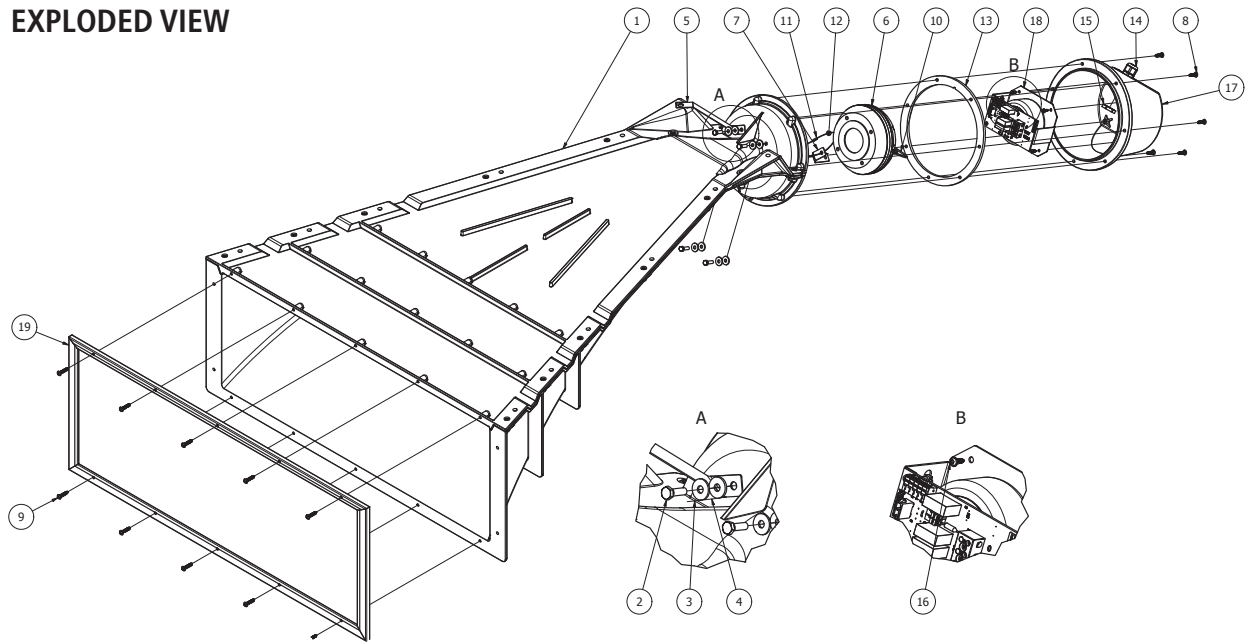

fig. 4: Exploded View.

Item	Qty	Description
1	1	ABF-260 horn assembly PA6-V0
2	4	Hex-Head Bolt, DIN 933 - M6 x 20 - RVS A4
3	4	Washer M6 - DIN 9021 - RVS A4
4	4	Washer 18 x 6,4 x 2 mm, PVC
5	1	ABF-260 Fall Protection bracket Outside
6	1	Duran 100 CD 2 Inch, 100Watt compression driver 8 ohms
7	1	ABF-260 Fall Protection bracket Inside
8	7	EJOT PT Button Head Flanged Screw,TX20, 5x20mm, A4
9	10	EJOT PT Button Head Flanged Screw,TX20, 5x25mm, A4
10	1	ABF-260 Driver cable assembly
11	1	Ferrule standard EN 13411-3, 2,0 mm aluminium
12	1	Steel rope 6x7 + 1 twk, 2 mm, galvanized, L=780
13	1	Gasket for ABF-260 Horn Sealing cover
14	1	Cable Gland Dome nut, Long threaded, Polyamide Black Pg13,5
15	1	Hexagonal Locknut, Polyamide Black Pg13,5
16	4	EJOT PT Button Head Flanged Screw,TX20, 4x12mm, Steel (Zinc Plated)
17	1	ABF-260 Horn Sealing Cover PA6
18	1	Transformer Assembly for ABF-260 horn PA6 model, Without EQ
19	1	Front Cover For ABF Horn, PA6 model H345

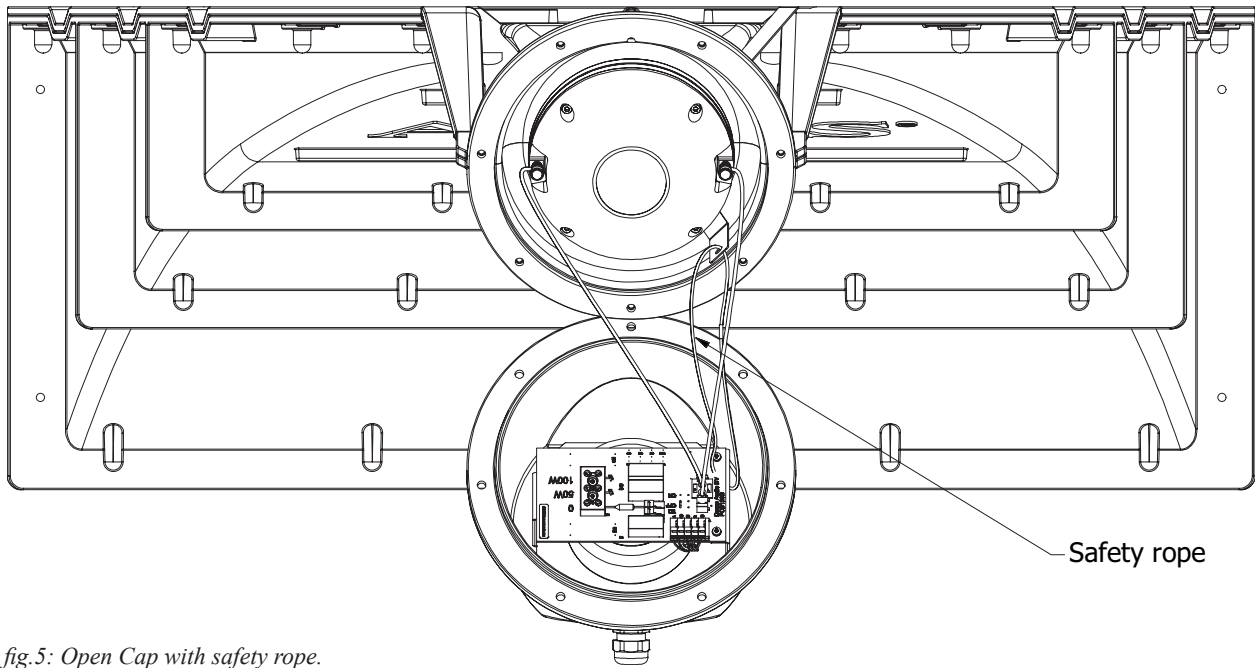

fig.5: Open Cap with safety rope.

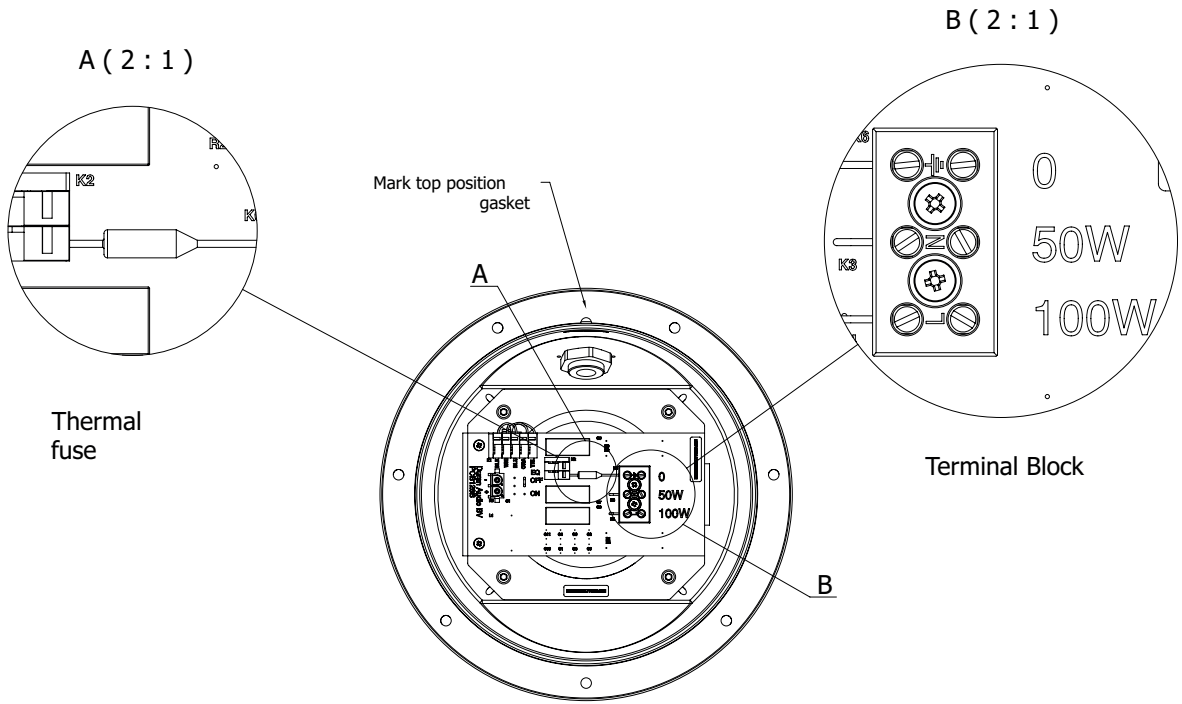

fig.6: Electrical Connections



www.axystunnel.com